

maskin mekano

**ECO3+**

CONTAINER MOBILE SCREENING PLANT





DECKS



2

SCREEN AREA



1.2 x 2.2

WEIGHT



14.000

TRANSPORT



Hook lift

CONSUMPTION



12 kWh



3 l/h

SET UP TIME



3 minutes

## Sustainable, powerful, versatile

With these guiding principles, we have developed the screening plant ECO3+. A modern machine for today's requirements where recyclability is key. In this environment with abrupt changes and at times small volumes, it is necessary to reduce costs to a minimum, and these costs are time, transport and fuel.

- Hook lift frame for lowest possible moving cost
- The belt feeder ensures an even and easily adjusted feeding speed
- Aggressive screen with 12 mm stroke also sorts damp materials with great efficiency
- Diesel electric operation provides the industry's lowest diesel consumption and CO<sub>2</sub> emissions
- The lowest noise levels in its class allows you to work in urban environments

We use technology, not to complicate things, but to make everyday life easier.











ADVANTAGES OF ALL OUR PLANTS:

CARBON FOOTPRINT



Electric drive  
OR low emissions

VIBRATIONFREE



The Vibroblock  
concept

SCREEN CAPACITY



Aggressive stroke

NOISE IMPACT



Very low

OPERATOR SAFETY



Protection according  
to regulations

OVERVIEW



Touchscreen in  
electrical cabinet

MADE IN SWEDEN



## Powerful belt feeder

The feed unit consists of a heavy-duty hopper and a powerful belt feeder providing an even and easily adjusted feeding speed. The hopper has a generous size (5 m<sup>3</sup>) for such a compact machine. The speed and the tipping of the reject grid is controlled via remote control. The distance between the reject grid bars is adjustable but is as standard 180 mm.

## Aggressive screen

The ECO3+ is equipped with Machine Mekano's proven screen STE 2-26. It has a 12 mm powerful stroke and the inclination is only 11°, which means cumbersome masses never run the risk of just sliding over the screen, but are efficiently processed by the aggressive stroke. The capacity per square metre screen area is unsurpassed in the industry. Changing meshes is cheap and quickly done, it is therefore profitable to run fairly small batches. The open construction gives full accessibility to the screen box for ease of maintenance and inspection.

The STE screen has an impressively wide range. It successfully screens light materials such as bark and wood chip. On account of the aggressive stroke, it is never clogged with damp masses like landfill and soil.

## Stockpiling

For stockpiling the plant is fitted with three hydraulically folded on-board conveyors. All drive drums are rubberized for safe operation even in less favourable weather conditions.

## Diesel-electric operation

The power source in ECO3+ is a diesel engine optimised for 1500 rpm. It runs quietly and economically. Diesel consumption is low at just 3 l/h, which translates into CO<sub>2</sub> emissions of about 9 kg/h. Noise levels from the machine vary according to the materials being sorted, but when empty the sound level is a class leading 70 dBA.

## Operations on mains power

If you have access to mains power, you do not need to run the diesel engine, which gives even cheaper and quieter production. The total power consumption at full production amounts to 24 A, which corresponds to an electricity consumption of approx. 14 kW/h.

## Professional service

Maskin Mekano's machines are known for their operating reliability. Together with our partners, you can expect a high level of technical support and fast delivery of spare parts, which are always stocked.

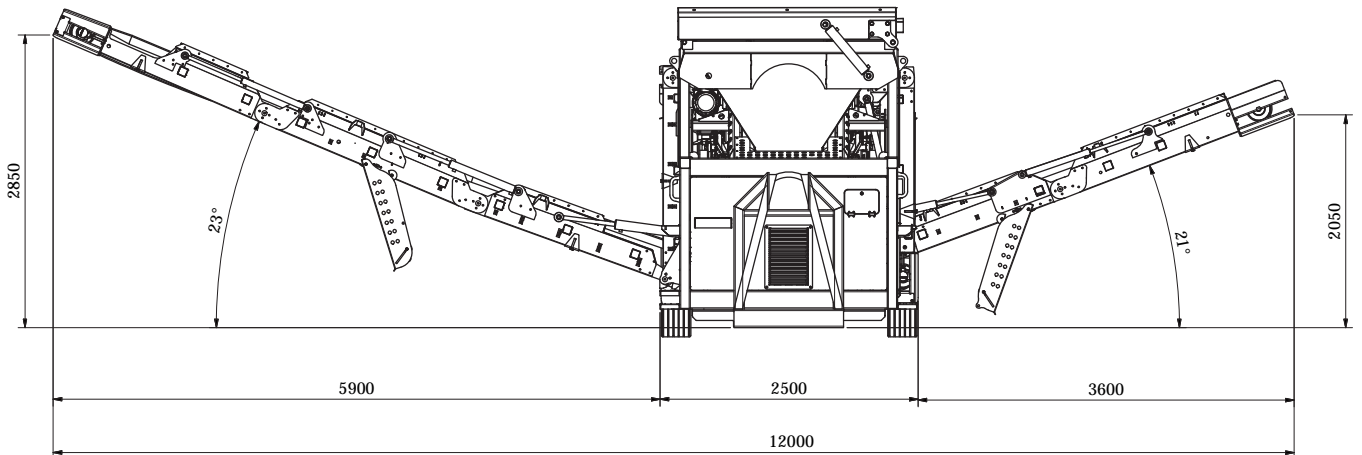
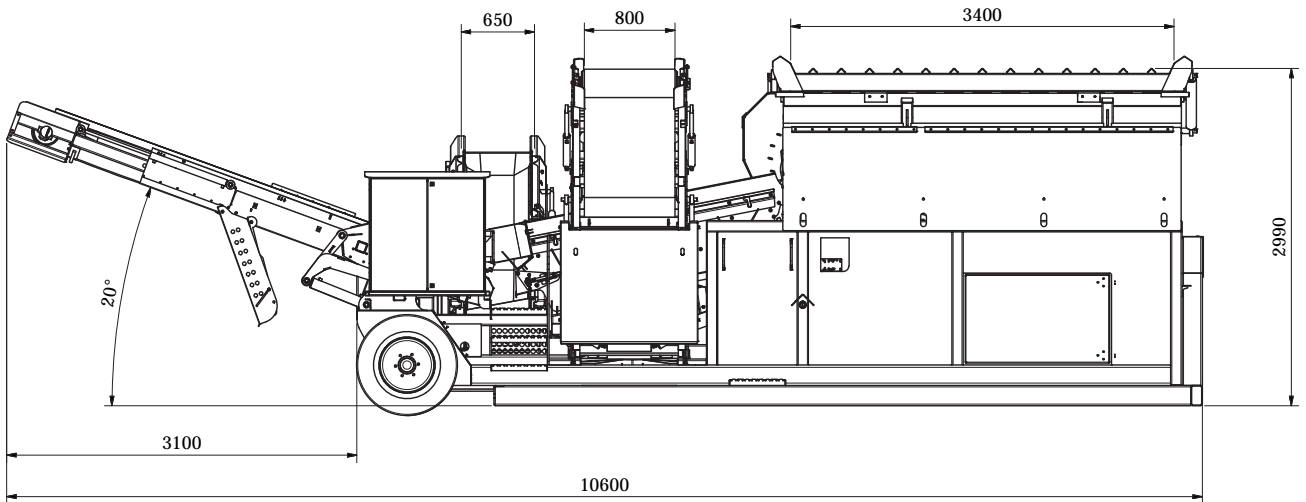
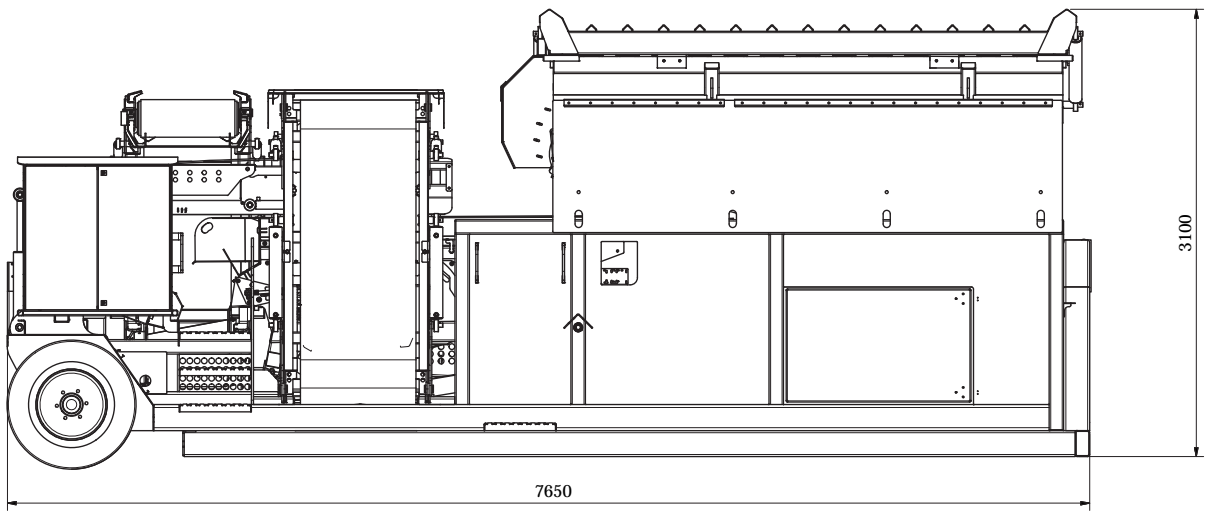

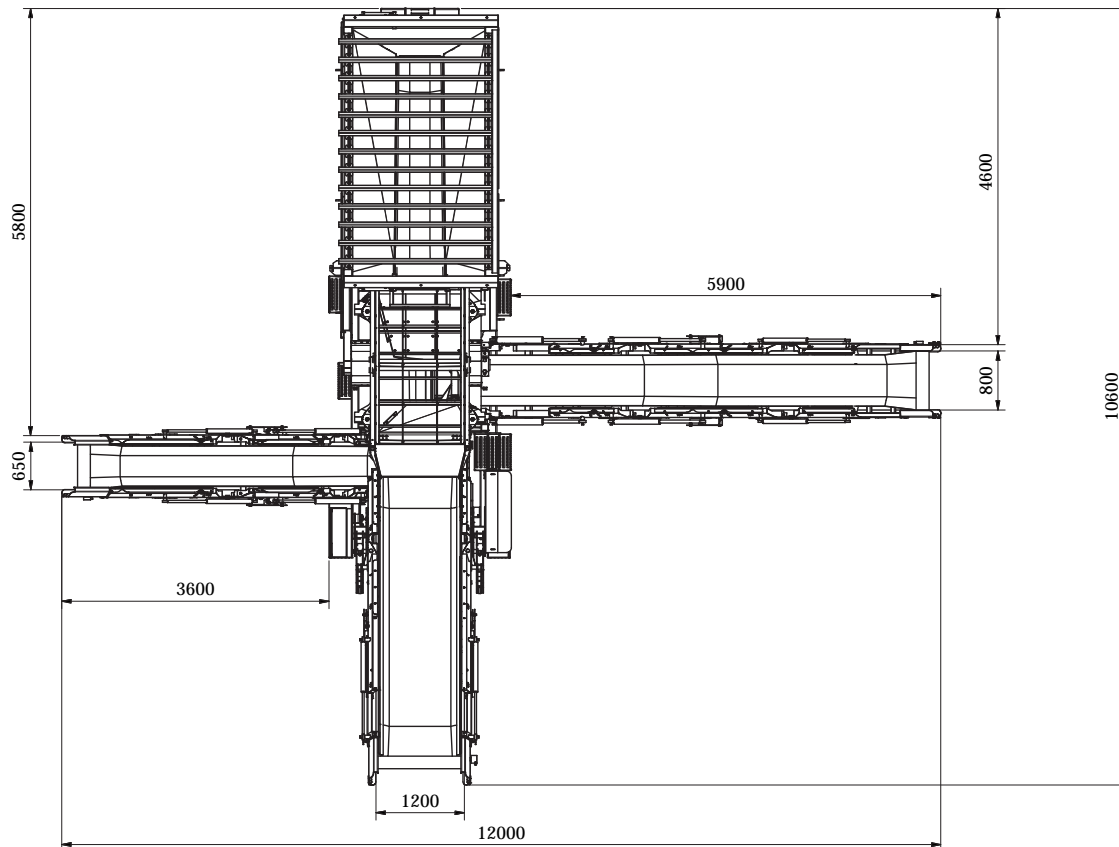

## FAQ

### What brand is the diesel motor?

It is an EU stage V, water cooled four cylinder motor driving a 35 kVA generator. The rotation speed is 1500 rpm, so it is both quiet and economic.

### How do you change the screening media?

The upper deck is side tensioned and fastened by 4 bolts. The lower deck is end tensioned and fastened by 2 bolts only. The nose of the screen is foldable for even better access of the lower deck. It is possible to perform the swap as a single operator and after a few times it takes no more than 15 minutes.

### What is the price of a new set of meshes?

Meshes for the upper deck normally cost 300-400 EUR. For the lower deck 250-300 EUR.

### What if I only want to produce one size?

Only use the upper deck for sorting and leave the lower deck empty. The tensioning profiles in the bottom deck need to be fastened in order to prevent wear and tear, the tensioning profile in the rear needs to be removed from the screen box.

### What is the feed-in-height of the hopper? What kind of loader is suitable?

The feed-in-height is 2.9 m and the reject grid is 3.4 m wide. A very suitable wheel loader is a Volvo L70, L90 or similar. It is absolutely possible to use a smaller loader, but a small access ramp will be needed.

### The difference between a belt feeder and a vibrating feeder?

A belt feeder (the ECO3+) has a great speed interval and is resistant to sticky and wet material, so if you are going to produce mostly top-soil it is a great choice. A vibrating feeder (the ECO3) is very sturdy and versatile and can process all kinds of recycling masses and heavier stones. The ECO3 is ideal for those who want to use it in many different applications.

### Is it possible to adjust the feeding speed?

Yes, the variable speed driver is controlled via the radio transmitter (also used for tipping of the reject grid).

### What parts usually need to be replaced?

The ECO3+ is a very robust plant featuring a lot of the same proven components as the larger Maskin Mekano plants. It is essential to retighten the screening media after a while to minimize the strain. If the filters and the oil of the motor are changed according to recommendations and the lubrication points are greased every 40th hour there is usually no need to replace any parts.

### How many lubrication points are there? Can it be fitted with centralized lubrication?

It is possible to fit the ECO3+ with centralized lubrication, but most customers chose not to since there are only 4 lubrication points that are very accessible and only need to be greased every 40th hour. To lubricate the bearings of the cylinders once every year is also recommended.

### What is the weight of the machine?

14 tons as standard, in Sweden and some countries it can be transported with a standard hook-lift bogie truck.

### What is the fuel consumption?

The ECO3+ has a fuel consumption of only 3 l/h.

### The machine is very quiet, how is that possible?

The rotation speed of the diesel generator is only 1500 rpm and it is also noise insulated. The screen box is mounted on a vibration damped frame which prevents the vibrations from the screen from transmitting to the chassis, this also contributes to the low noise impact.

### How long is the set-up-time?

For transport mode the feeder is lowered and the conveyors folded, this is done hydraulically without any need for any manual handling. It is ready for transport in 3 minutes and ready for production in the same time.

### And the capacity?

The capacity when producing top soil is 30-150 tones/h, depending on how moist the material is. For other materials (like sand and gravel) the capacity is usually between 100-200 tones/h.

## Technical Specification Maskin Mekano ECO3+

<i>Transport Length</i>	7.65 m
<i>Transport Width</i>	2.5 m
<i>Transport Height</i>	3.1 m
<i>Machine Weight</i>	approx. 14 tons, depending on equipment
<i>Screenbox</i>	STE 2-26 E Screening surface 1.2 x 2.2 m on two decks Single axle mechanically controlled with 12 mm stroke 11° incline Motor 4.0 kW, 400 V
<i>Belt feeder</i>	Width 1000 mm Effect 3.0 kW Hopper volume 5 m <sup>3</sup>
<i>Oversize conveyor</i>	Belt width 1200 mm Length 5.3 m Drummotor 3.0 kW Height under the drum drive 2.4 m
<i>Midsize conveyor</i>	Belt width 650 mm Length 5.3 m Drummotor 3.0 kW Height under the drum drive 2.1 m
<i>Fines conveyor</i>	Belt width 800 mm Length 7.5 m Drummotor 4.0 kW Height under the drum drive 2.9 m
<i>Hydraulic equipment</i>	Hydraulic aggregate for setup of machine and tipping of reject grid. Motor 4.0 kW
<i>Electric equipment</i>	Electrical distribution box with integrated touchscreen mounted on the machine. Start button for sequence start. Transformer for control current. Emergency stop on the conveyors. Interlock chain. Electrical socket for 230/400 V equipment.
<i>Driving package</i>	Dieselmotor EU stage V, 1500 RPM. Generator 42 kVA/50 Hz
<i>Wheel- and towing device</i>	Mounted on a hook-lift chassis

*Our policy is one of continuous improvement and we reserve the right to change the detailed specification of our products at any time without prior notice.*

*The family owned business Maskin Mekano is based in Jönköping in the South of Sweden. Maskin Mekano was founded in 1956 and has delivered high quality equipment to the screening, crushing and contracting industries ever since. Maskin Mekano is the Swedish market leader in mobile screening due to the unique screen (which combines high capacity and high accuracy because of the aggressive stroke) and renown for robust, reliable and user friendly machines. All Maskin Mekano screening plants are fully electric. Spare parts are stocked in Jönköping. Maskin Mekano is your partner for productivity.*

# maskin mekano

Address: Maskin Mekano AB, Box 9083, 550 09 Jönköping, SWEDEN,

Phone: + 46 36 31 74 00

E-mail: [info@maskinmekano.se](mailto:info@maskinmekano.se)

[www.en.maskinmekano.se](http://www.en.maskinmekano.se)